

UPS³

Development of a UTRAN
Protocol & Network Simulator



Renato Lo Cigno

Dipartimento di Elettronica
Gruppo di Ricerca Reti di Telecomunicazione
Politecnico di Torino
www.tlc-networks.polito.it

UPS³



- **U**TRAN
- **P**rotocol
- **S**tack
- **S**tochastic
- **S**imulator

UPS³ - Omnitel-Vodafone - May 29 2002

UPS³



- Philosophy of the Project
- General Architecture of the Simulator
 - Physical Layer, MAC, RLC, RRC, Upper
- Structure existing at the beginning of the project
- Year 1 Milestones
- Year 2 Forecasts

UPS³ - Omnitel-Vodafone - May 29 2002



Philosophy & Aims

- Develop a research/advanced engineering tool
- Focus on algorithms and quantitative results
- Address mainly the Radio Level Protocols
- Attention on new data services, where the interaction with non-UMTS protocols may heavily affect performance
- Simplify (through models) all the parts deemed non essential (physical layer & signaling functions above all)

UPS² - Omnitel-Vodafone - May 29 2002



Goals & not

- What it does (will do) ...
 - Analyse interface performance
 - Quantify throughputs, delays, ...
 - Quantify protocol efficiency
 - Help dimensioning buffers
 - Help optimise services
 - Identify architecture weaknesses (propose remedies)
 - Extrapolate user satisfaction from network dimensioning

UPS² - Omnitel-Vodafone - May 29 2002



Goals & not

- ... and what it does not (will never!)
 - Plan cell resources
 - Certify procedures
 - Include a detailed GIS database
 - Perform physical layer simulations with bit/chip detail

UPS² - Omnitel-Vodafone - May 29 2002

General Architecture

- Only one RNS modeled
- Arbitrary number of users and services
- Five main "layers"
 - physical, MAC, RLC, RRC, Upper
- Two main entities
 - UE (mobile users)
 - UTRAN (the network)
- Textual I/O (for the time being!)

UPS² - Omnitel-Vodafone - May 29 2002

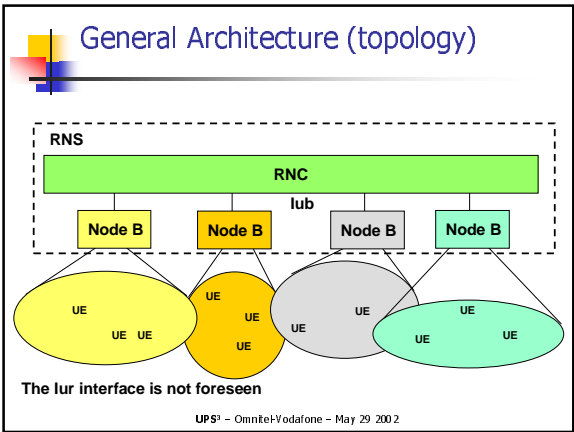

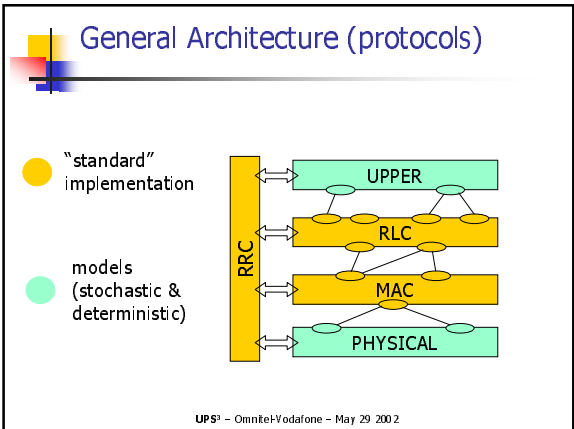

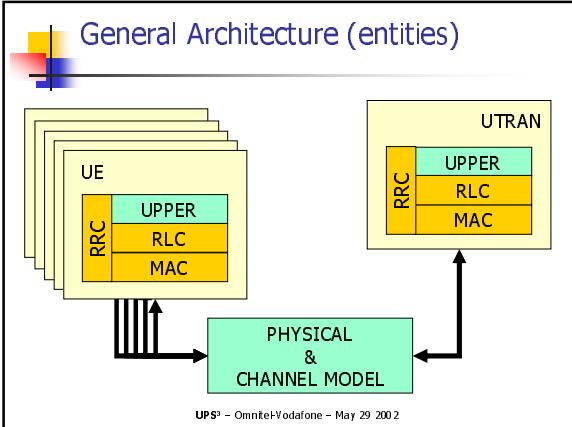

- ### General Architecture (language & paradigm)
- C++
 - Modular architecture (reasonably independent entities)
 - Mixed time/event driven
 - Frame (10ms) based evolution
 - Advanced event list management for efficiency
 - Sound pseudo-random driving engine
 - Batch means stochastic analysis of results
- UPS² - Omnitel-Vodafone - May 29 2002

- ### Physical Layer
- Regular, folded topology (constraint can be relaxed)
 - Omni/Multidirectional antennas
 - Arbitrary radiation diagrams
 - Random/Constrained walk mobility model
 - Simulation space divided in pixel of arbitrary size for best tradeoff between precision & efficiency
 - Standard Gaussian Approx. for interference (simpler on/off models can be re-included)
 - Arbitrary BLER curves (service-specific curves can be included)
- UPS² - Omnitel-Vodafone - May 29 2002



Medium Access Control

- MAC-d (one per UE and one each UE in the UTRAN)
- MAC-c/sh
- Support dedicated and contention channels
- Transport format selection
- Priority selection
- Mux/Demux of logical traffic channels

UPS[®] - Omnitel-Vodafone - May 29 2002



MAC-d implementation

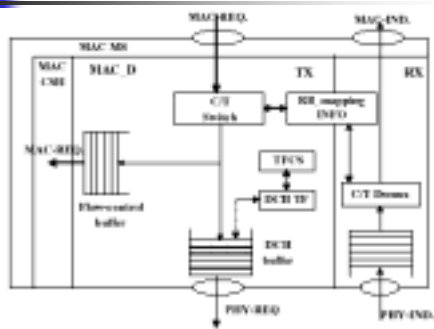

UPS[®] - Omnitel-Vodafone - May 29 2002



MAC-c/sh implementation (UE)

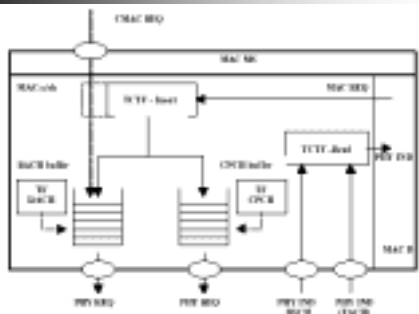

UPS[®] - Omnitel-Vodafone - May 29 2002

MAC-c/sh implementation (UTRAN)

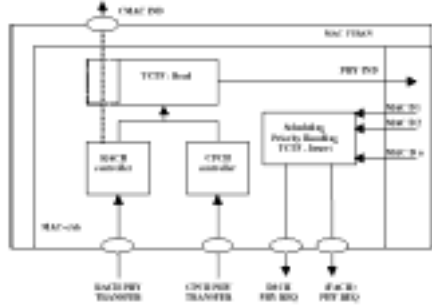

UPS² - Omnitel-Vodafone - May 29 2002

Radio Link Control

- Standard implementation
- Transparent, Unacknowledged, Acknowledged
- Segmentation, Concatenation, Padding

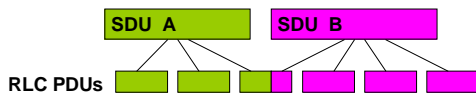

- No cyphering

UPS² - Omnitel-Vodafone - May 29 2002

Radio Link Control (transparent)

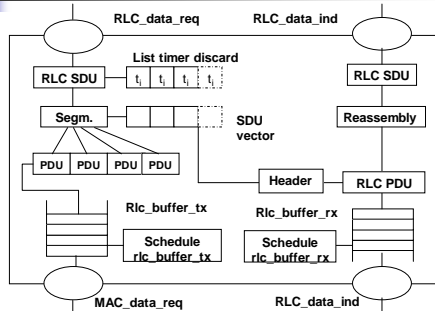

UPS² - Omnitel-Vodafone - May 29 2002



Radio Resource Control (functions)

- RRC Connection setup, control and tear-down
- Radio Bearer setup, release and reconfiguration
 - Data transmission suspend & reactivate
 - Bit-rate modification
- Radio resource control & management
- QoS control
- Traffic monitoring
- Transmission channel monitoring

UPS[®] - Omnitel-Vodafone - May 29 2002



Radio Resource Control (basic model)

Routing Function Entity
Transfer Mode Entity
Control
Control Function Entity

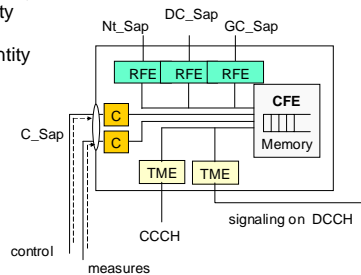

UPS[®] - Omnitel-Vodafone - May 29 2002



Upper Layer

- Simple stochastic traffic generators
 - Exponential, Constant, ...
- Streaming services over UDP
 - Markovian multi-state model interacting with RRC for quality analysis
- Data over TCP
 - Sophisticated TCP model with flow & congestion control algorithms
- Half duplex TCP & UDP implementations (no data on the reverse connection)

UPS[®] - Omnitel-Vodafone - May 29 2002

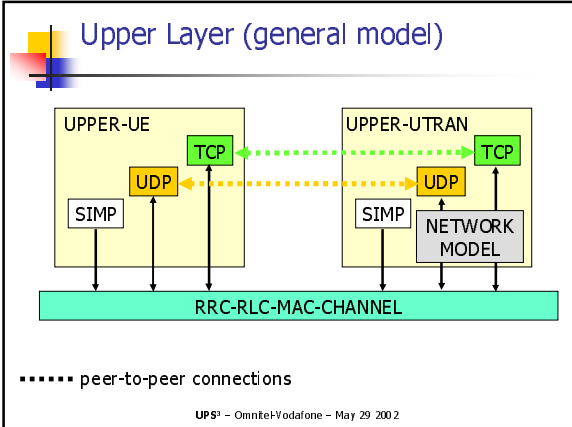

- ### Measures
- Probe-based measuring infrastructure (non necessary measures are not probed and do not slow the simulation)
 - Time plots + histogram data analysis
 - Measured quantities can be submitted to stochastic analysis
 - Results stability drives the simulation duration
- UPS² - Omnitel-Vodafone - May 29 2002

- ### Starting Point
- Simulator engine (almost complete)
 - Physical Layer
 - Folded topology description
 - Trivial Channel Model (on-off)
 - Unconstrained Random Walk Mobility
 - MAC
 - Implemented but untested
- UPS² - Omnitel-Vodafone - May 29 2002

Starting Point

- RLC
 - Simplified Description (with many bugs!)
- RRC
 - None
- Upper
 - None
- Mesures
 - None

UPS² - Omnitel-Vodafone - May 29 2002

Year 1 Milestones

- Physical Layer
 - Standard Gaussian Interferent Aproximation with separate uplink and downlink BLER description
 - Constrained Random Walk Mobility
 - Interface with RRC
- MAC
 - Testing
 - Interface with RRC

UPS² - Omnitel-Vodafone - May 29 2002

Year 1 Milestones

- RLC
 - Completely rewritten based on "experience"
 - Transparent, UnACK & ACK mode tested
 - Interface with RRC
- RRC
 - Written & Tested
 - Interface with Physical, RLC, MAC & Upper

UPS² - Omnitel-Vodafone - May 29 2002



Year 1 Milestones

- Upper
 - Simple sources
 - Definition of TCP & UDP models
- Measures
 - **Probing structure & strategy defined and implemented**
 - **Stochastic analysis imported**
- Some simulation on selected scenarios

UPS³ - Omnitel-Vodafone - May 29 2002



Possible Future Activities

- **TCP/UDP Upper model implementation & testing**
- Topology constraint relaxation
- **Interferent/BLER model improvements**
- Additional mobility models
- **Run simulations on case-studies**
- Improve handover model
- Include macrodiversity models
- Design a graphical interface
- ...

UPS³ - Omnitel-Vodafone - May 29 2002



UPS³

- A short introduction to the research group
- Philosophy of the Project
- General Architecture of the Simulator
 - Physical Layer, MAC, RLC, RRC, Upper
- Structure existing at the beginning of the project
- Year 1 Milestones
- Year 2 Forecasts
- **Discussion**

UPS³ - Omnitel-Vodafone - May 29 2002
